

SPECIFICATION

A: MATERIAL:

- 1. BODY: NYLON 66
- 2. TERMINAL: Cu PLATED Sn
- 3. PIN: Cu PLATED Ni
- 4. COVER: PC

B: CHARACTERISTICS:

- 1. RATING: 2.5A 250V~(C-ULus, ENEC & CCC, KC)
- 2. INSULATION RESISTANCE: 100MΩ MIN. AT 500VDC
- 3. ELECTRIC STRENGTH : AC 3,000 V/1 MIN, LEAKAGE CURRENT UNDER 0.5mA

C: APPROVALS: C-ULus, ENEC & CCC KC

- D: MATERIAL USED MUST BE COMPLY WITH HQI-0010
- E: CAN MEET ROHS, HF

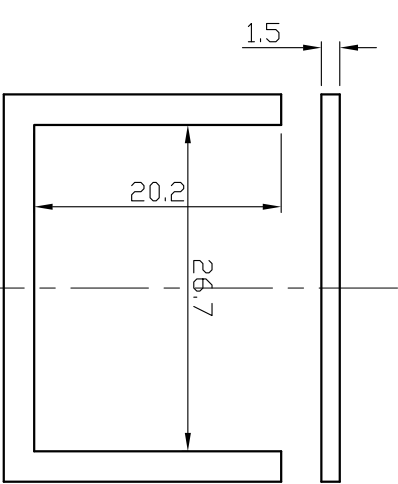
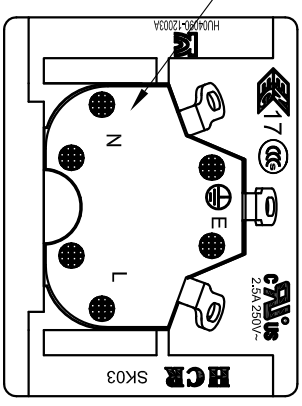
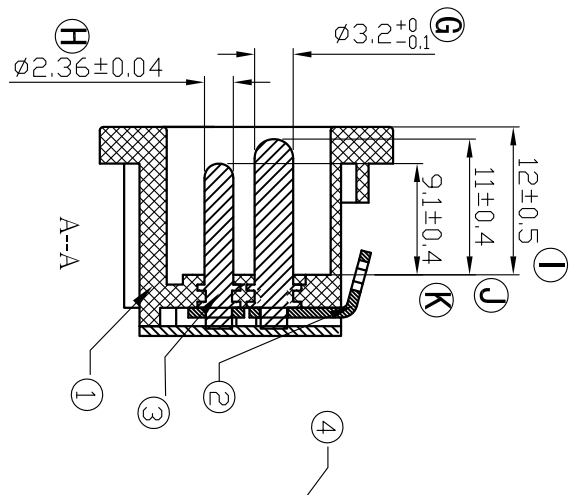
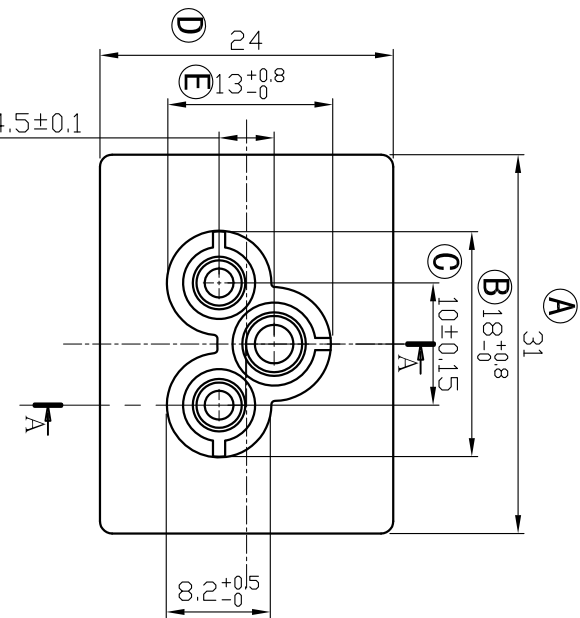

PANEL CUT-OUT

TOLERANCES UNLESS OTHERWISE	
未指定容許差尺寸之公差	
BASIC DIMENSIONS TOLERANCES	
UP TO 10 (10以下)	±0.1
ABOVE 10 TO 30 (10-30)	±0.3
ABOVE 30 TO 100 (30-100)	±0.5
ANGULAR DIMENSIONS(角度)	±5°
DIMENSION UNIT	mm

NO	DATE	REVISION DESCRIPTION	REVISION	RD/AVIN	APPROVED
0	2012/11/14	新制訂	A0	Weichen	AaronJin
1					
2					

東莞市華之力電子有限公司 DONGGUAN HCR ELECTRONICS CO., LTD.	
核准	AaronJin
校對	RZTang
繪圖	Weichen
日期	20110705
日期	20110705
日期	20110705
投影法	第一角
比例	1:1
圖號	SK03
料號	SK03-0401040121CH